



PART NUMBER: 11596.04
PRODUCT: Nerf step
APPLICATION: 18-Jeep JL 4 Door

460 HORIZON DR. | SUWANEE, GA 30024 | PHONE: 770-614-6101 | FAX: 770-614-6069 | www.omix-ada.com



HARDWARE DESCRIPTION	QTY.
KIT# HWK-00010X	
M8x30mm flanged hex bolt with washer	6
M8x25mm Flanged hex head bolt (Black zinc)	12
M8 flanged nuts	12

Step 1. Identify the driver side step.

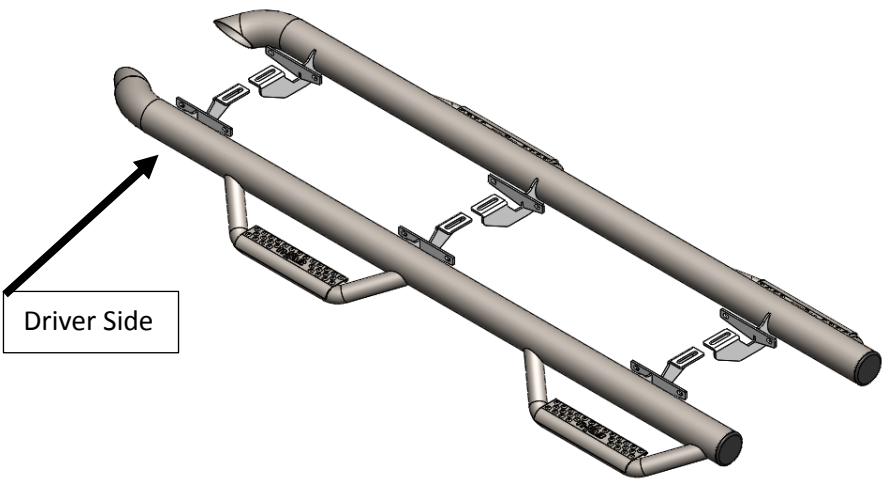

OMIX-ADA® TECHNICAL SUPPORT

PHONE: M-F 8am - 5pm EST 1-800-449-6649 | TICKET: webmaster@omixsupport.com

Step 2. Remove the factory running boards and discard.



Step 3. Starting with driver side step; carefully raise up into position and align the brackets with the factory mounting points with the horizontal part of the bracket on the outside of the pinch weld.

Step 4. Next, start one of the supplied M8x30mm hex head flanged bolt and washer starting with the center bracket in the factory threaded hole and leave loose.

Step 5. Start two M8x25mm black zinc flanged bolts and two M8 flanged nuts in the pinch weld and leave loose for final adjustment.



Step 6. Continue installing the rest of the hardware in the remaining brackets and leave loose.

Step 7. Adjust the nerf-step where the main bar is level with the body of the vehicle.

Step 8. First, tighten all the hardware that attaches the bracket to the pinch weld of the vehicle.



Step 9. Next, tighten the remaining hardware that attaches the bracket to the upper body mount.



Step 10. Repeat steps 4-9 for the Driver side.